



This certification form must be completed by a "BPU Certified" Plumber or Grease Waste Hauler.

### GREASE TRAP ANNUAL CERTIFICATION (Form B)

Every food service establishment in the Paris Board of Public Utilities water and wastewater service area must have their grease trap (under-the-sink units) certified annually, as required by their FOG Permit, to verify that all components of the grease control equipment are present and in good working condition.

Facility Name: \_\_\_\_\_ Phone #: \_\_\_\_\_

Address: \_\_\_\_\_ City: \_\_\_\_\_, TN. Zip Code \_\_\_\_\_

- |  | <u>PASS</u>              | <u>FAIL*</u>             |
|--|--------------------------|--------------------------|
| 1. Grease trap completely emptied and cleaned before inspection?                           | <input type="checkbox"/> | <input type="checkbox"/> |
| -----  |                          |                          |
| 2. There is access to all trap chambers for cleaning?                                      | <input type="checkbox"/> | <input type="checkbox"/> |
| -----  |                          |                          |
| 3. Flow restrictor device is installed (before grease trap or at grease trap inlet)?       | <input type="checkbox"/> | <input type="checkbox"/> |
| -----  |                          |                          |
| 4. Flow restrictor device installation is correct (proper flow direction and orientation)? | <input type="checkbox"/> | <input type="checkbox"/> |
| -----  |                          |                          |
| 5. Grease trap is vented (vent on flow restrictor)?  | <input type="checkbox"/> | <input type="checkbox"/> |
| -----  |                          |                          |
| 6. Grease trap has NO visible holes or leaks?  | <input type="checkbox"/> | <input type="checkbox"/> |
| -----  |                          |                          |
| 7. Baffle(s) (inlet, middle and outlet...depending on design) are secure and operational?  | <input type="checkbox"/> | <input type="checkbox"/> |
| -----  |                          |                          |
| 8. Automatic or machine dishwasher is <u>NOT</u> connected to the grease trap?             | <input type="checkbox"/> | <input type="checkbox"/> |
| -----  |                          |                          |
| 9. No Sewer clean-out covers missing or damaged?   | <input type="checkbox"/> | <input type="checkbox"/> |

**\* IMPORTANT REQUIRED INFORMATION & RESPONSE:** If the answer to any of the above questions is "Fail", the equipment has failed certification. A statement of the plan of action to be taken, with date to be completed, needs to be provided on attached sheet under "Response Comments" (attach additional sheets to explain corrective action if necessary):

**Inspector Certification** - This grease trap has  PASSED  FAILED certification.

I \_\_\_\_\_ of \_\_\_\_\_  
*(print name of inspector)* *(print company name)*

certify that the above listed facility has a \_\_\_\_\_ gallons per minute / \_\_\_\_\_ pound capacity grease trap. I have examined the grease trap and provided the above information.

\_\_\_\_\_  
*(signature)* *(date)* *(phone number)*

#### **Facility Owner/Manager Certification**

I \_\_\_\_\_ certify to the best of my knowledge the above  
*(print name)*

statements to be true and correct. \_\_\_\_\_  
*(signature)* *(date)*

**SUBMIT ORIGINAL FORM TO: Paris Board of Public Utilities, P.O. Box 460, Paris, TN 38242**

M  
U  
S  
T  
  
C  
O  
M  
P  
L  
E  
T  
E  
  
A  
L  
L  
  
I  
N  
F  
O  
R  
M  
A  
T  
I  
O  
N

**Under the Sink Grease Trap Diagram**

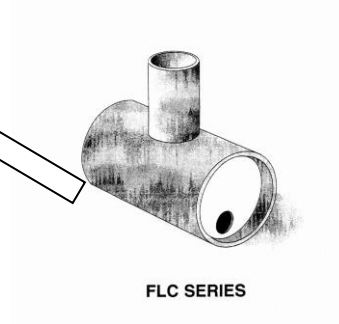
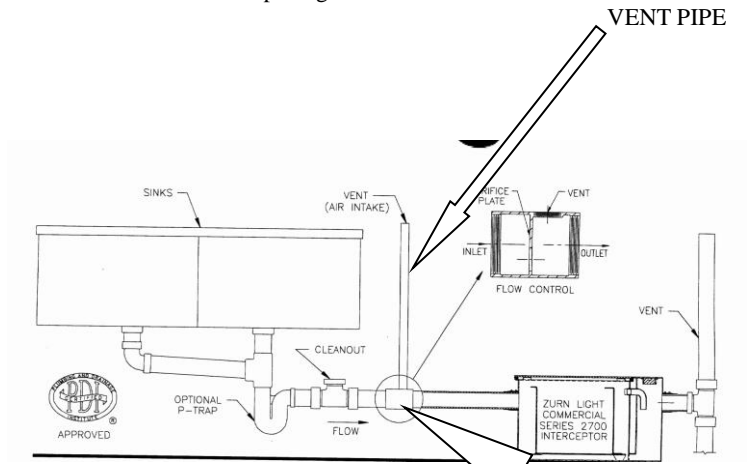

*FLOW RESTRICTOR (Key component)*

***RESPONSE COMMENTS (required if “Fail” checked, identify problem, corrective action and provide planned date of corrective action)***

---



---



---



---



---



---



---



---



---



---



---